

Copying of this document and giving it to others and the use or communication of the contents thereof, are forbidden without express authority. Offenders are liable to the payment of damages. All rights are reserved in the event of the grant of a patent or the registration of a utility model or design.

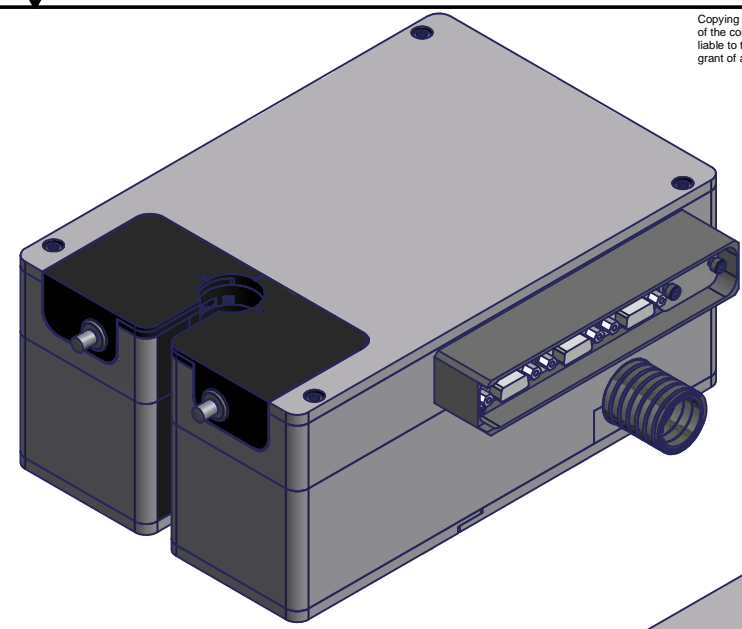

Einbaulage
installed location

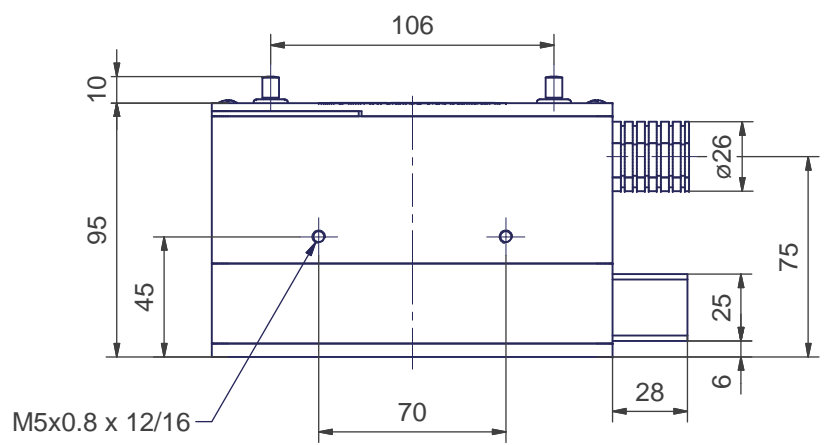
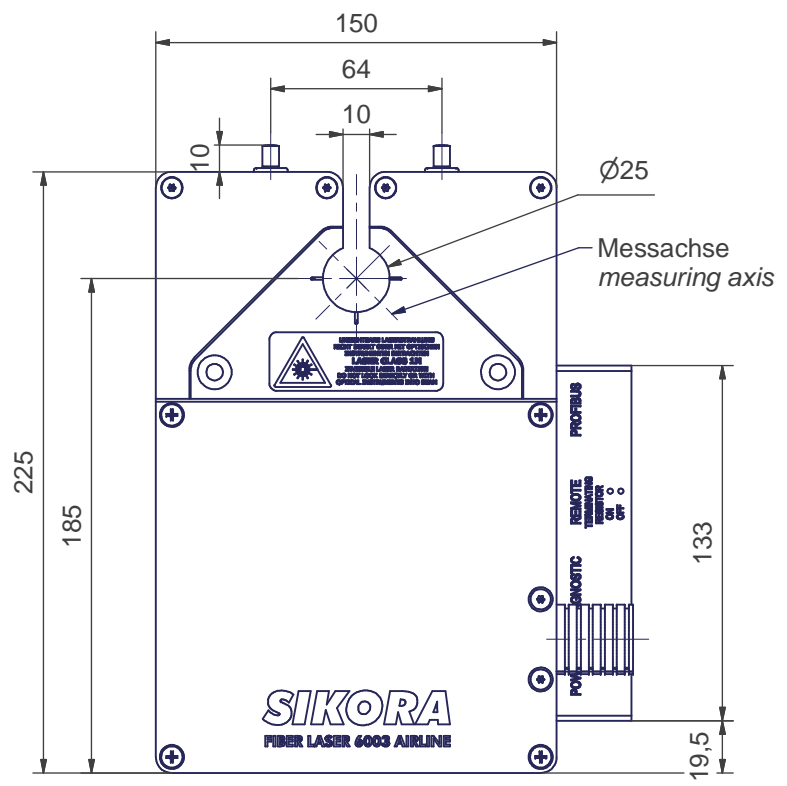
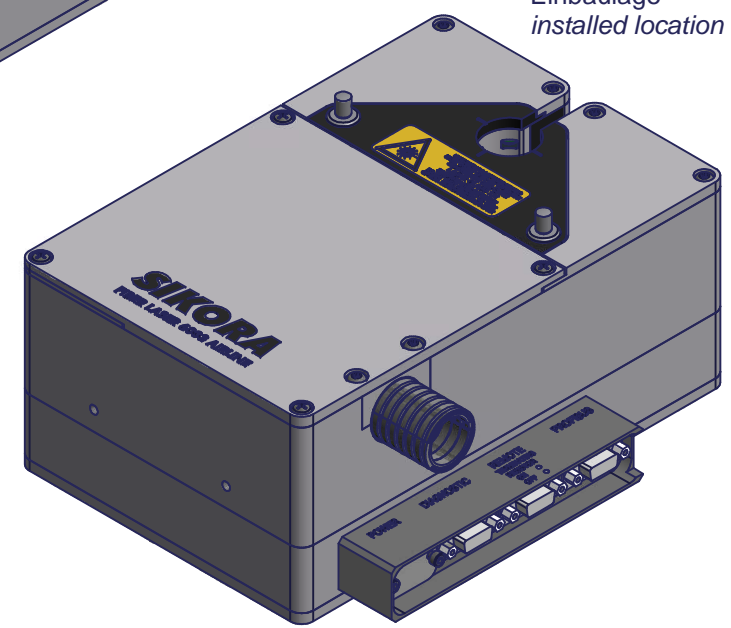

Identnummer / Part no.		Allgemeintoleranzen General tolerances		Maßstab / Scale 1:2		Gewicht / Weight 4,685 kg	
		ISO 2768-					
		Date		Name		Benennung / Title	
		08.07.2014		K.Dröge		Messkopf FIBER LASER 6003 AIRLINE	
		Checked				Verkauf / for selling	
		Approved					
						Zeichnungsnummer / Dwg no.	
						GE0300M2227	
						Blatt / Sheet	
						1 / 1	
						Original size	
						DINA3	
Rev	Modification	Date	Name	File GE0300M2227 Messkopf Fiber Laser 6003 Airline.idw / GE0300M2227			

SIKORA
FIBER LASER 6003 AIRLINE

SIKORA
Technology To Perfection

SIKORA AG Bruchweide 2 28307 Bremen Germany